



## 30CTQ.../30CTQ...S /30CTQ...-1 SCHOTTKY RECTIFIER

### Features

- 150°C T<sub>j</sub> operation
- Center tap configuration
- Low forward voltage drop
- High purity, high temperature epoxy encapsulation for enhanced mechanical strength and moisture resistance
- High frequency operation
- Guard ring for enhanced ruggedness and long term reliability
- Terminals finish: Tin Lead-free plated
- This is a Pb - Free Device
- All SMC parts are traceable to the wafer lot
- Additional testing can be offered upon request

### Applications

- Switching power supply
- Converters
- Free-Wheeling diodes
- Reverse battery protection

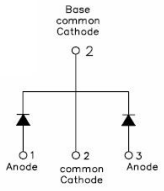
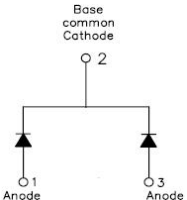
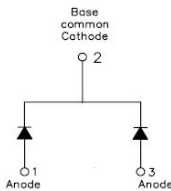
30CTQ...	30CTQ...S	30CTQ...-1
		
		
TO-220AB	D <sup>2</sup> PAK	TO-262

### Maximum Ratings@T<sub>c</sub>=25°C unless otherwise specified

Characteristics	Symbol	Condition	Max.	Units
Peak Repetitive Reverse Voltage Working Peak Reverse Voltage DC Blocking Voltage	V <sub>RRM</sub> V <sub>RWM</sub> V <sub>R</sub>	-	30(30CTQ030) 35(30CTQ035) 40(30CTQ040) 45(30CTQ045)	V
Average Rectified Forward Current	I <sub>F(AV)</sub>	50% duty cycle @T <sub>c</sub> =105°C, rectangular wave form	15(Per Leg) 30(Per Device)	A
Peak One Cycle Non-Repetitive Surge Current(Per Leg)	I <sub>FSM</sub>	8.3ms, Half Sine pulse	318	A

### Electrical Characteristics:

Characteristics	Symbol	Condition	Typ.	Max.	Units
Forward Voltage Drop (Per Leg)*	V <sub>F1</sub>	@ 15A, Pulse, T <sub>J</sub> = 25 °C	0.51	0.62	V
	V <sub>F2</sub>	@ 15A, Pulse, T <sub>J</sub> = 125 °C	0.45	0.56	V
Reverse Current (Per Leg)*	I <sub>R1</sub>	@V <sub>R</sub> = rated V <sub>R</sub> T <sub>J</sub> = 25 °C	0.05	1.0	mA
	I <sub>R2</sub>	@V <sub>R</sub> = rated V <sub>R</sub> T <sub>J</sub> = 125 °C	27	40	mA
Junction Capacitance(Per Leg)	C <sub>T</sub>	@V <sub>R</sub> = 5V, T <sub>C</sub> = 25 °C f <sub>SIG</sub> = 1MHz	702	900	pF

\* Pulse width < 300 μs, duty cycle < 2%

### Thermal-Mechanical Specifications:

Characteristics	Symbol	Condition	Specification	Units
Junction Temperature	T <sub>J</sub>	-	-55 to +150	°C
Storage Temperature	T <sub>stg</sub>	-	-55 to +150	°C
Typical Thermal Resistance Junction to Case	R <sub>θJC</sub>	DC operation	3.25	°C/W
Typical Thermal Resistance, Case to Heat Sink	R <sub>θJL</sub>	DC operation	0.50	°C/W
Case Style	TO-220AB D <sup>2</sup> PAK TO-262			

### Tube Specification

Device	Package	Weight	Shipping
30CTQ...	TO-220AB	1.8g	50pcs / tube
30CTQ...S	D <sup>2</sup> PAK	1.85g	800pcs / reel
30CTQ...-1	TO-262	1.85g	50pcs / tube

For information on tape and reel specifications, including part orientation and tape sizes, please refer to our tape and reel packaging specification.

### Tube Specification(TO-220AB/TO-262)

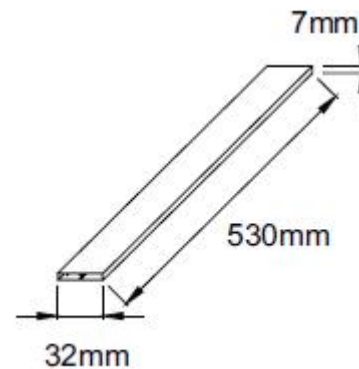

**Ratings and Characteristics Curves**

Figure 1 Typical Forward Characteristics

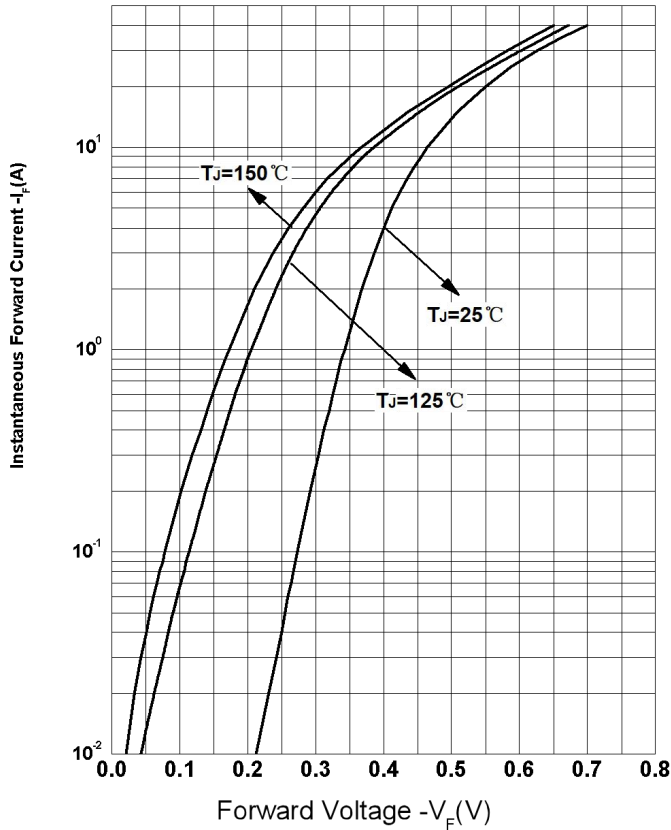

Figure 2 Typical Reverse Characteristics

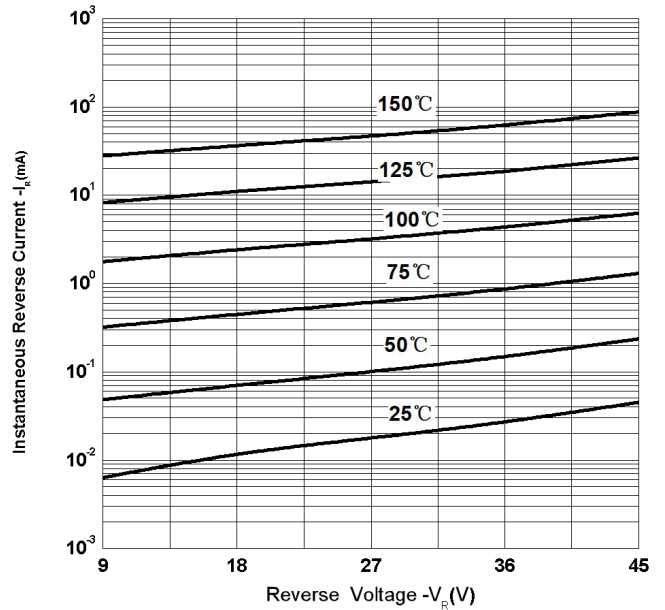
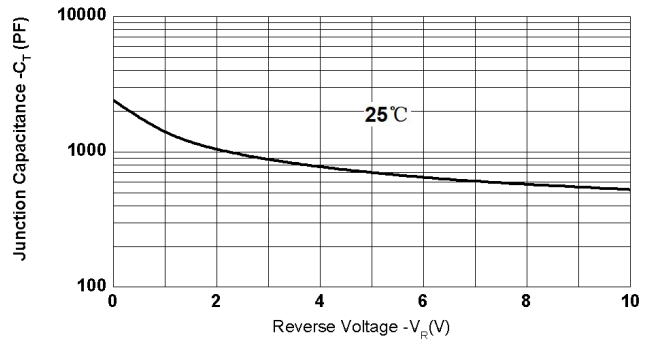
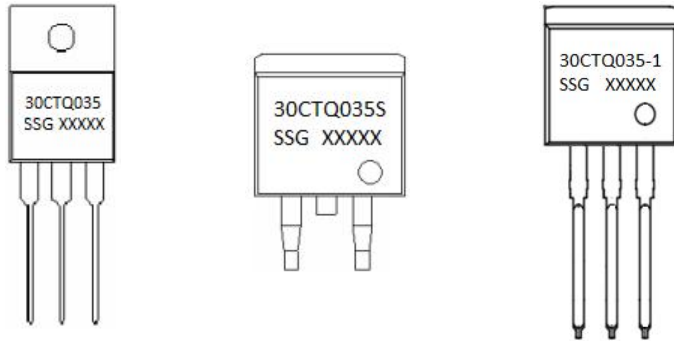

Figure 3 Typical Junction Capacitance



## Marking Diagram



Where XXXXX is YYWWL

30 = Forward Current (30A)  
C = Configuration  
TQ = Device Type  
30/35/40/45 = Reverse Voltage (30V/35V/40V/45V)  
S/-1 = Package type  
SSG = SSG  
YY = Year  
WW = Week  
L = Lot Number

**Cautions:** Molding resin  
Epoxy resin UL94V-0

## Carrier Tape Specification D<sup>2</sup>PAK

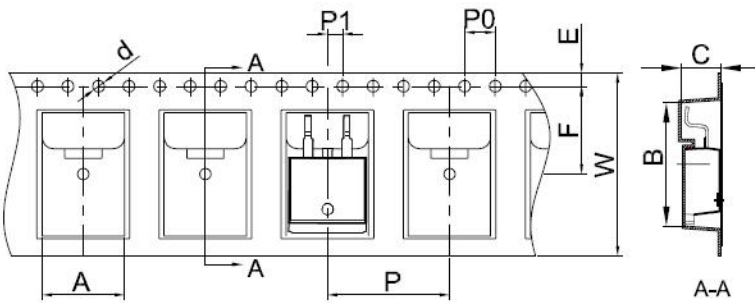

Symbol	Millimeters	
	Min.	Max.
A	10.70	10.90
B	16.03	16.23
C	5.11	5.31
d	1.45	1.65
E	1.65	1.85
F	11.40	11.60
P0	3.90	4.10
P	15.90	16.10
P1	1.90	2.10
W	23.90	24.30

## Mechanical Dimensions TO-220AB

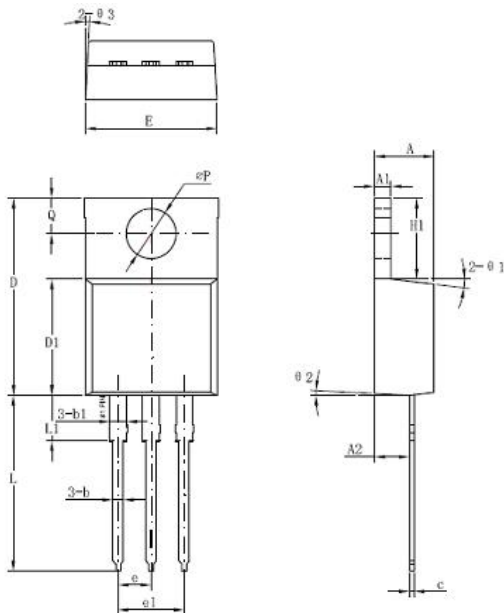

Symbol	Dimensions in millimeters		
	Min	Typical	Max
A	3.56	-	4.83
A1	0.51	-	1.4
A2	2.03	-	2.92
b	0.38	-	1.02
b1	1.14	-	1.78
c	0.31	-	0.61
D	14.22	-	16.51
D1	8.38	-	9.42
E	9.65	-	10.67
e	-	2.54	-
e1	-	5.08	-
H1	5.84	-	6.86
L	12.7	-	14.73
L1	-	-	6.35
phi P	-	3.56	-
Q	2.54	-	3.43

**Mechanical Dimensions D<sup>2</sup>PAK**

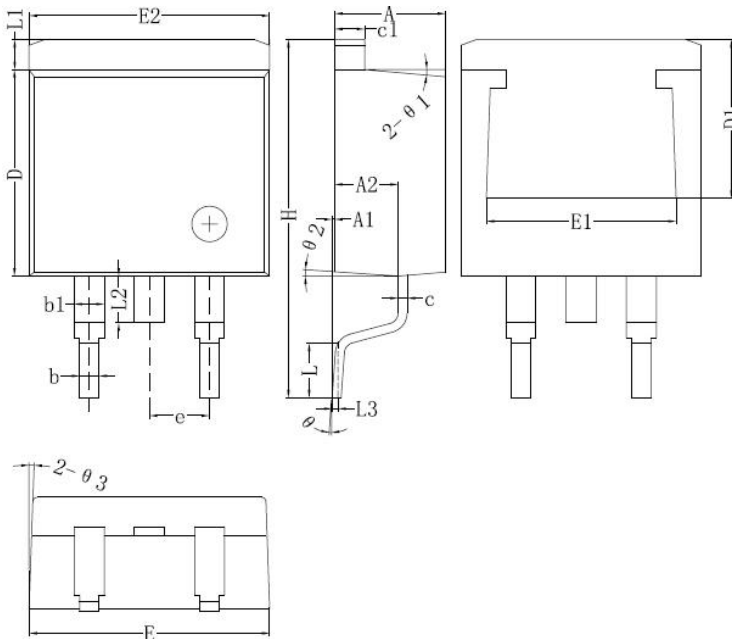

Symbol	Dimensions in millimeters	
	Min.	Max.
A	4.06	4.83
A1	0	0.26
b	0.51	0.99
b1	1.14	1.78
c	0.31	0.74
c1	1.14	1.65
D	8.38	9.65
D1	6.4	
E1	6.22	
E2	9.65	10.67
e	2.54BSC	
H	14.6	15.88
L	1.78	2.8
L1	-	1.68
L2	-	2.2
L3	0.255BSC	
θ	0	8°

**Mechanical Dimensions TO-262**

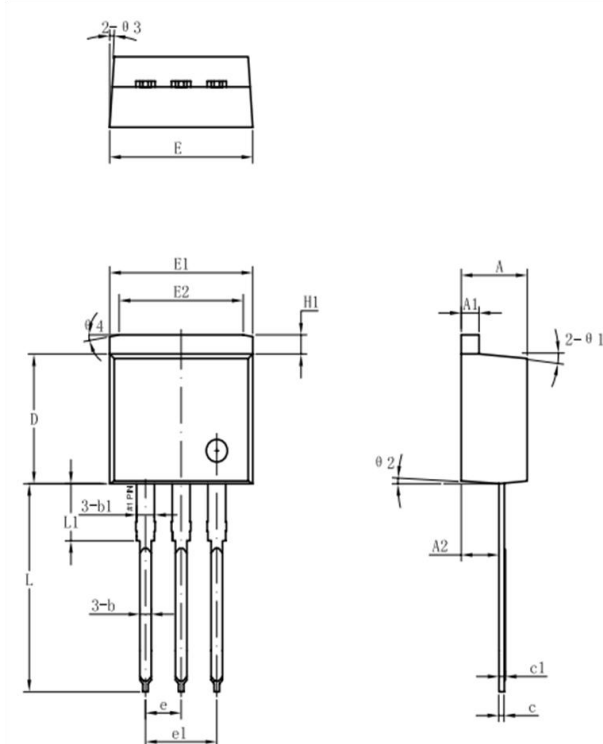

Symbol	Millimeters		
	Min.	Typical	Max.
A	4.55	4.70	4.85
A1	1.17	1.27	1.37
A2	2.59	2.69	2.89
B	1.22	1.37	1.47
b	0.71	0.81	0.96
b1		1.27	
c	0.36	0.38	0.61
D	8.55	8.70	8.85
E	10.01	10.16	10.31
E1	9.88	10.08	10.28
e		2.54	
e1		5.08	
H1	1.17	1.27	1.37
L	13.00	13.86	14.08
L1		3.8	
θ1		5°	
θ2		4°	
θ3		4°	
θ4		10°	



**DISCLAIMER:**

- 1- The information given herein, including the specifications and dimensions, is subject to change without prior notice to improve product characteristics. Before ordering, purchasers are advised to contact the SMC Diode Solutions sales department for the latest version of the datasheet(s).
- 2- In cases where extremely high reliability is required (such as use in nuclear power control, aerospace and aviation, traffic equipment, medical equipment, and safety equipment), safety should be ensured by using semiconductor devices that feature assured safety or by means of users' fail-safe precautions or other arrangement.
- 3- In no event shall SMC Diode Solutions be liable for any damages that may result from an accident or any other cause during operation of the user's units according to the datasheet(s). SMC Diode Solution assumes no responsibility for any intellectual property claims or any other problems that may result from applications of information, products or circuits described in the datasheets.
- 4- In no event shall SMC Diode Solutions be liable for any failure in a semiconductor device or any secondary damage resulting from use at a value exceeding the absolute maximum rating.
- 5- No license is granted by the datasheet(s) under any patents or other rights of any third party or SMC Diode Solutions.
- 6- The datasheet(s) may not be reproduced or duplicated, in any form, in whole or part, without the expressed written permission of SMC Diode Solutions.
- 7- The products (technologies) described in the datasheet(s) are not to be provided to any party whose purpose in their application will hinder maintenance of international peace and safety nor are they to be applied to that purpose by their direct purchasers or any third party. When exporting these products (technologies), the necessary procedures are to be taken in accordance with related laws and regulations..