

8SQ045 SCHOTTKY BARRIER RECTIFIER

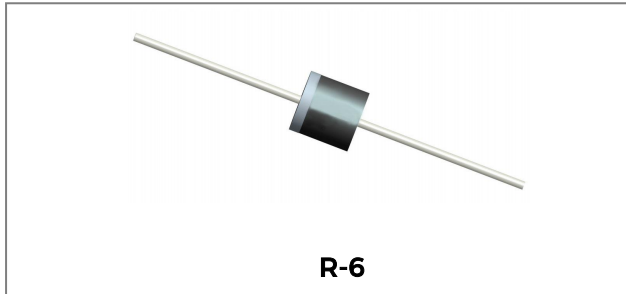

Features

- Super-high speed & low noise switching
- Low voltage drop
- Terminals finish: Tin Lead-free plated
- This is a Pb - Free Device
- All SMC parts are traceable to the wafer lot
- Additional testing can be offered upon request

Circuit Diagram



Mechanical Data

- DC-DC converters
- AC adapter
- High frequency rectification circuit
- Bypass diodes

Maximum Ratings ($T_c = 25^\circ\text{C}$ unless otherwise specified)

Characteristics	Symbol	Condition	Max.	Units
Peak Repetitive Reverse Voltage	V_{RRM}	-	45	V
Working Peak Reverse Voltage	V_{RWM}			
DC Blocking Voltage	V_R			
Average Rectified Forward Current	$I_{F(AV)}$	$T_L = 116^\circ\text{C}$, In DC	8	A
Peak One Cycle Non-Repetitive Surge Current	I_{FSM}	8.3 ms, half Sine pulse	200	A

Electrical Characteristics:

Characteristics	Symbol	Condition	Typ.	Max.	Units
Forward Voltage Drop*	V_{F1}	@ 8 A, Pulse, $T_j = 25^\circ\text{C}$	0.50	0.53	V
	V_{F2}	@ 8 A, Pulse, $T_j = 125^\circ\text{C}$	-	0.44	V
Reverse Current*	I_{R1}	@ $V_R = \text{rated } V_R, T_j = 25^\circ\text{C}$	0.03	1.0	mA
	I_{R2}	@ $V_R = \text{rated } V_R, T_j = 125^\circ\text{C}$	15	60.0	mA
Junction Capacitance	C_T	@ $V_R = 5\text{V}, T_c = 25^\circ\text{C}$ $f_{SIC} = 1\text{MHz}$	500	900	pF

* Pulse width < 300 μs , duty cycle < 2%

Thermal-Mechanical Specifications:

Characteristics	Symbol	Condition	Specification	Units
Junction Temperature	T_J	-	-55 to +150	$^{\circ}\text{C}$
Storage Temperature	T_{stg}	-	-55 to +150	$^{\circ}\text{C}$
Typical Thermal Resistance, Case to Heat Sink	$R_{\theta JA}$	-	18	$^{\circ}\text{C}/\text{W}$
Typical Thermal Resistance, Junction to lead	$R_{\theta JL}$	-	8	$^{\circ}\text{C}/\text{W}$
Approximate Weight	wt	-	2.24	g
Case Style	R-6			

Ratings and Characteristics Curves

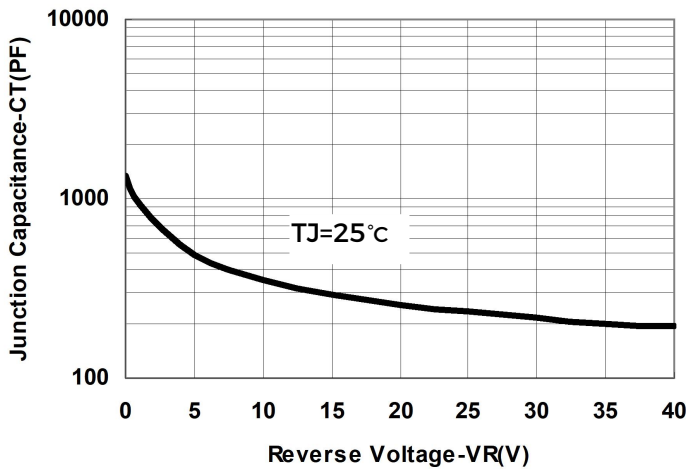

Fig.1-Typical Junction Capacitance

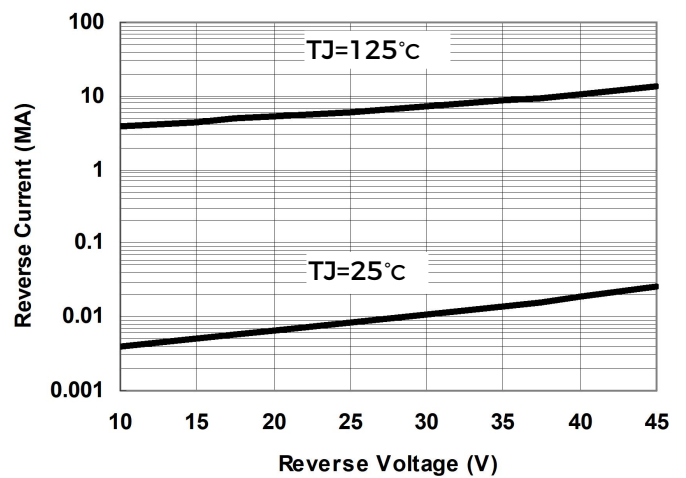

Fig.2-Typical Values Of Reverse Current

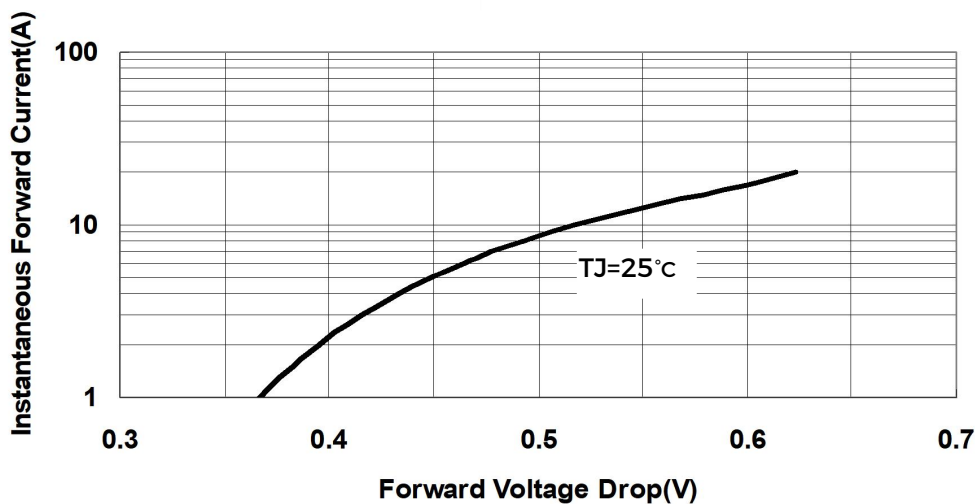
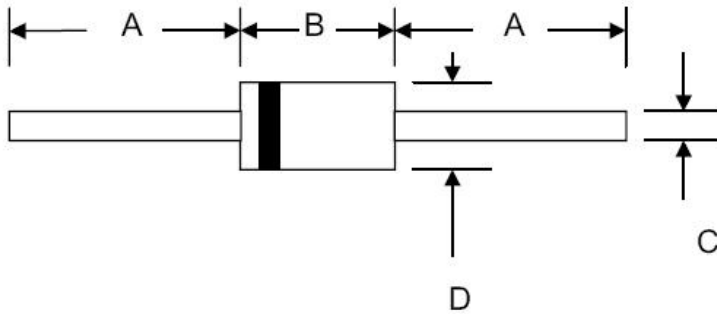

Fig.3-Typical Instantaneous Forward Voltage Characteristics

Mechanical Dimensions R-6



SYMBOL	Millimeters		Inches	
	Min.	Max.	Min.	Max.
A	25.4	-	1.000	-
B	8.60	9.10	0.340	0.360
C	1.2	1.3	0.048	0.052
D	8.60	9.10	0.340	0.360

Ordering Information

Device	Package	Shipping
8SQ045	R-6(Pb-Free)	500pcs / reel

For information on tape and reel specifications, including part orientation and tape sizes, please refer to our tape and reel packaging specification.

Marking Diagram

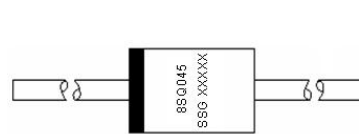

Where XXXXX is YYWWL

- 8 = Forward Current (8A)
- S = Package Type
- Q = Device Type
- 045 = Reverse Voltage (45V)
- SSG = SSG
- YY = Year
- WW = Week
- L = Lot Number

Cautions: Molding resin
Epoxy resin UL94V-0

Carrier Tape Specification R-6

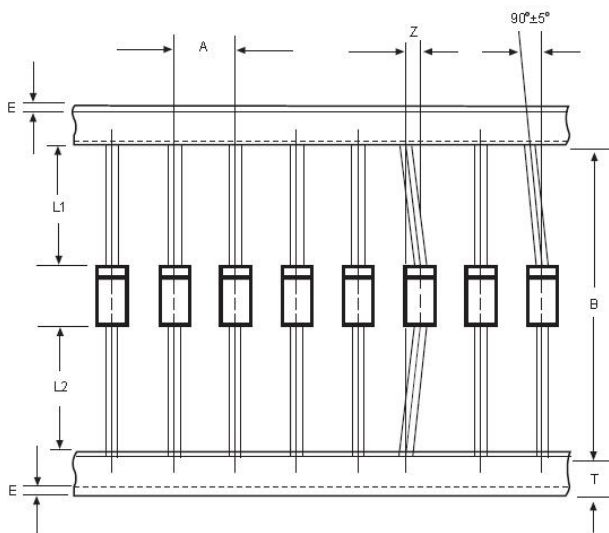

SYMBOL	Millimeters	
	Min.	Max.
A	9.50	10.50
B	50.9	53.9
Z	-	1.20
T	5.60	6.40
E	-	0.80
IL1-L2I	-	1.0

**DISCLAIMER:**

- 1- The information given herein, including the specifications and dimensions, is subject to change without prior notice to improve product characteristics. Before ordering, purchasers are advised to contact the SMC Diode Solutions sales department for the latest version of the datasheet(s).
- 2- In cases where extremely high reliability is required (such as use in nuclear power control, aerospace and aviation, traffic equipment, medical equipment, and safety equipment), safety should be ensured by using semiconductor devices that feature assured safety or by means of users' fail-safe precautions or other arrangement.
- 3- In no event shall SMC Diode Solutions be liable for any damages that may result from an accident or any other cause during operation of the user's units according to the datasheet(s). SMC Diode Solution assumes no responsibility for any intellectual property claims or any other problems that may result from applications of information, products or circuits described in the datasheets.
- 4- In no event shall SMC Diode Solutions be liable for any failure in a semiconductor device or any secondary damage resulting from use at a value exceeding the absolute maximum rating.
- 5- No license is granted by the datasheet(s) under any patents or other rights of any third party or SMC Diode Solutions.
- 6- The datasheet(s) may not be reproduced or duplicated, in any form, in whole or part, without the expressed written permission of SMC Diode Solutions.
- 7- The products (technologies) described in the datasheet(s) are not to be provided to any party whose purpose in their application will hinder maintenance of international peace and safety nor are they to be applied to that purpose by their direct purchasers or any third party. When exporting these products (technologies), the necessary procedures are to be taken in accordance with related laws and regulations..